



**HYDROPATH  
MARINE**



ELECTRONIC WATER CONDITIONERS

# Installation Guide

**IMPORTANT**

Read these instructions before fitting

**CUSTOM  
HM RANGE**  
BY HYDROPATH®



# Electrical Specifications

**Input Voltage** 87-240V AC (100 -230 VAC Nominal)

**Input Frequency** 47-63 Hz (50-60 Hz Nominal)

## Material Specifications

Main unit: Anodised Aluminium  
End plates: UL V-0 rated polycarbonate

## Water and Dust Protection

IP Rating: IP68 IEC 60529 (Transducer unit) IP66 IEC 60529 (Junction box)

## Built-in EMI Filter

Meets: FCC 20780 Class B  
VDE 0871 Level A

**Type Approval** DNV Certificate TAP00002RN

## Safety

Europe and Worldwide: IEC 60335-1/ EN 60335-1  
USA: UL60335-1  
Canada: CSA-C22.2 No:60335-1

## Overvoltage Category II

## Environmental Specifications

Installation category:  
Cat II; Altitude: <2000 Mtrs (6562'); Operating Temperature: -20 to + 55° C (-4 to 131°F);  
Maximum relative humidity; Max 100% up to 55°C (131° F)

**Overload Protection** Continuous short or open circuit on all outputs.

**Insulation** Basic insulation with the metal enclosure bonded to earth.

## Servicing

No user repairable parts are fitted. Repair must be undertaken by an authorised repair centre.

## Panel Indicators

The unit is fitted with LED indicator lights. The Green LED indicates that the power is on, and the Red indicates that a signal is being transmitted.

This appliance can be used by children aged from 8 years and above and persons with reduced physical, sensory or mental capabilities, or lack of experience and knowledge, if they have been given supervision or instruction concerning the use of the appliance in a safe way and understand the hazards involved. Children shall not play with the appliance. Cleaning and user maintenance shall not be made by children unless they are older than 8 years and supervised.

### ***NRTL Certification and CB Test Certificate***

In accordance with the  
International (IEC) and  
NRTL standards listed  
above.



Manufactured to BSEN9002

To be installed in accordance with the  
latest IEE wiring instructions.  
*Fuse rating: 1A.*



To be installed in accordance with the  
latest IEE wiring instructions.  
*Fuse rating: 1A.*

# Electrical Specifications

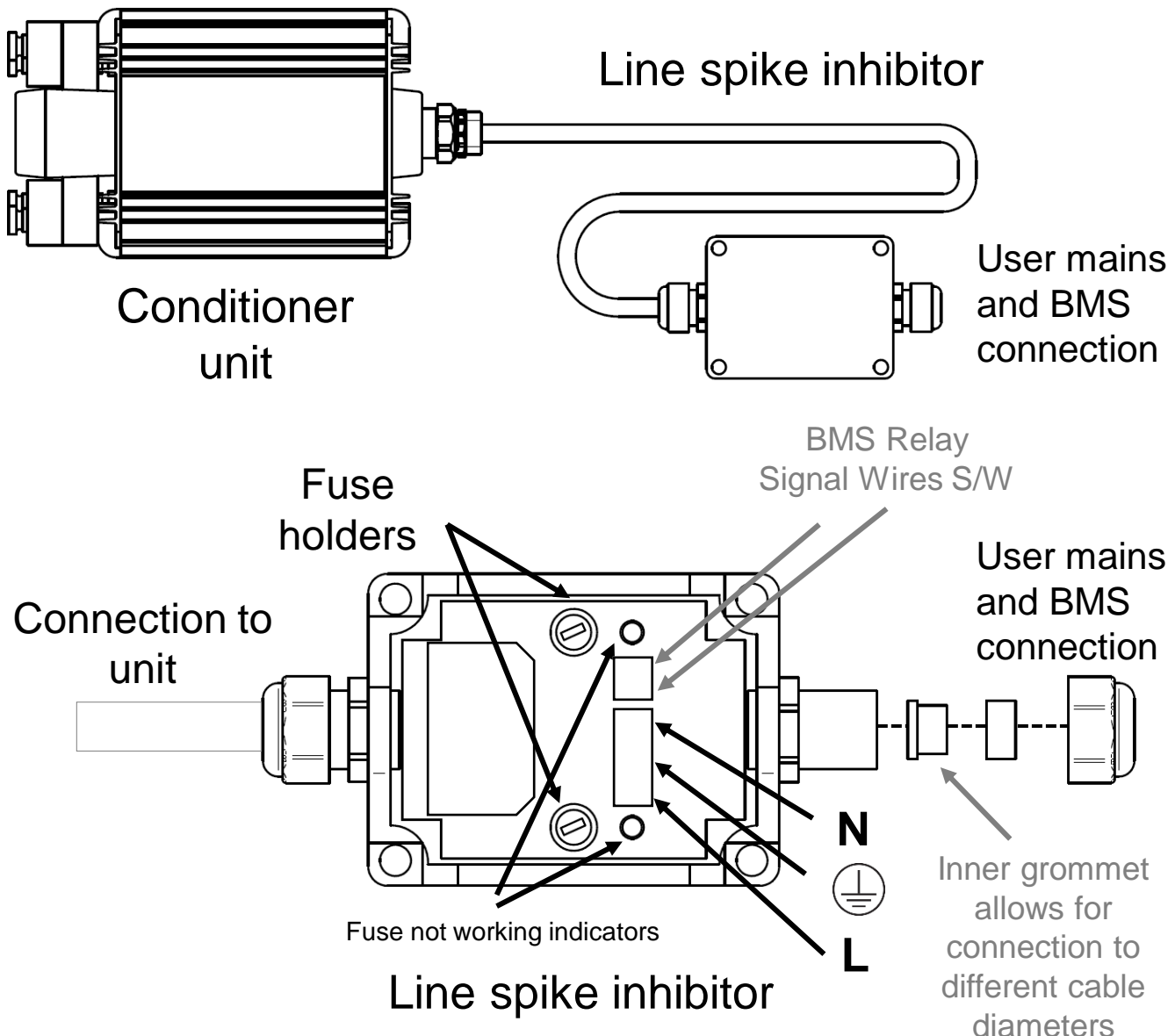

## Remote Monitoring Facility

A volt-free normally-open contact closure is provided by the unit connection with a BMS (Business Management System) computer, to monitor that the unit is operating correctly. Connection to the BMS output is made via the junction box. A suitable 5 core approved cable must be used in order to make connection to the mains input and the BMS output.

## Electrical Connection

The user must connect the electrical supply to the junction box in accordance with the on-site ruling safety legislation at the time of installation. The power supply must be isolated, for example via an isolating switch or circuit breaker. This is the sole responsibility of the user and the site safety officer must be consulted before installation is undertaken.

This equipment has no user serviceable parts. Return to supplier for servicing. If the equipment is used in a manner not specified by these instructions, the protection provided by the equipment may be impaired

# Assembly

## DO NOT POWER UP UNIT UNTIL ALL FERRITES SUPPLIED ARE CONNECTED.

POWERING THE UNITS WITHOUT FERRITES WILL INVALIDATE THE WARRANTY

- The unit is supplied with a bracket for ease of mounting to the pipe. The two upper plates should be loosely secured with bolts before installation.

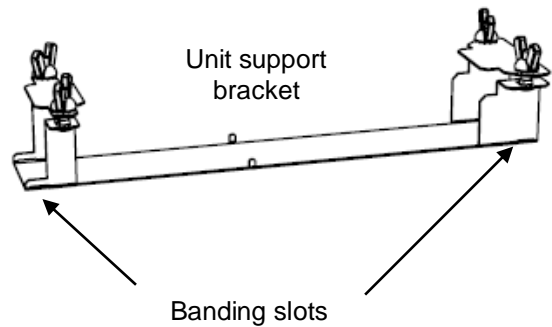

- Pass the two stainless steel bands through the slots in the bracket.
- Then pass the banding through the slots in the ferrite support bracket or brackets.

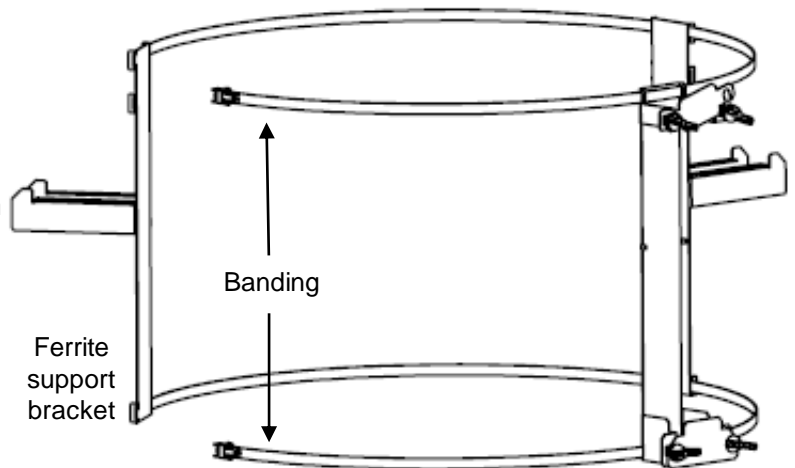

- Place the brackets around the pipe approximately evenly.
- Secure straps by tightening clamps with flathead screwdriver or hex socket driver

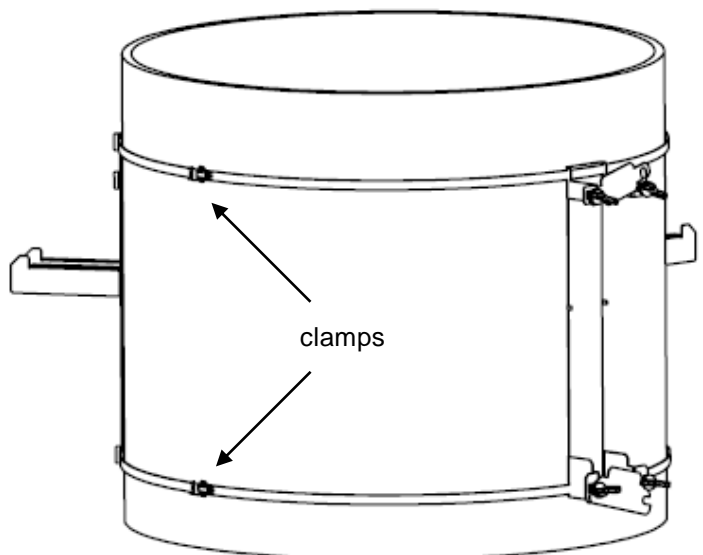

### **WARNING**

The system must be used as specified. Failure to do so will prevent correct operation of device and may impair safety.

# Assembly

## DO NOT POWER UP UNIT UNTIL ALL FERRITES SUPPLIED ARE CONNECTED.

POWERING THE UNITS WITHOUT FERRITES WILL INVALIDATE THE WARRANTY

- Place the unit on the bracket and hold in place using the swinging plates.
- Secure by tightening the four steel nuts.

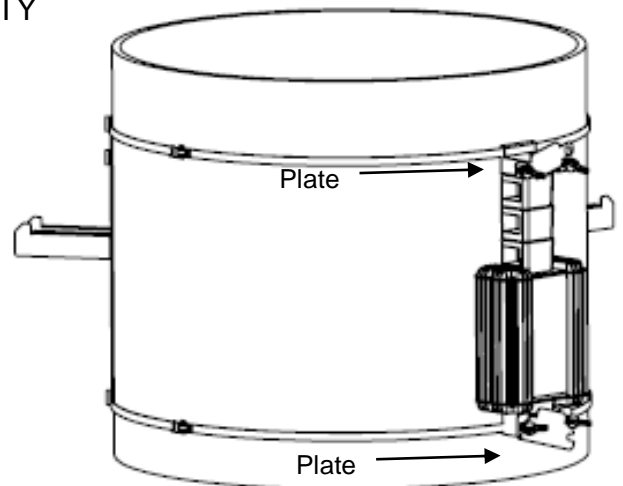

- Insert the two hexagon nuts into the holes in the end plate, next to the ferrite holding cage.
- If installing on a vertical pipe, place the unit with the ferrite cage upwards to ease fitting of hexagon nuts.
- Insert one of the ferrite bars through each hole in the holding cage until the holes line up with the hexagon nuts. For the custom 8 inch unit, ensure these are the two long bars.

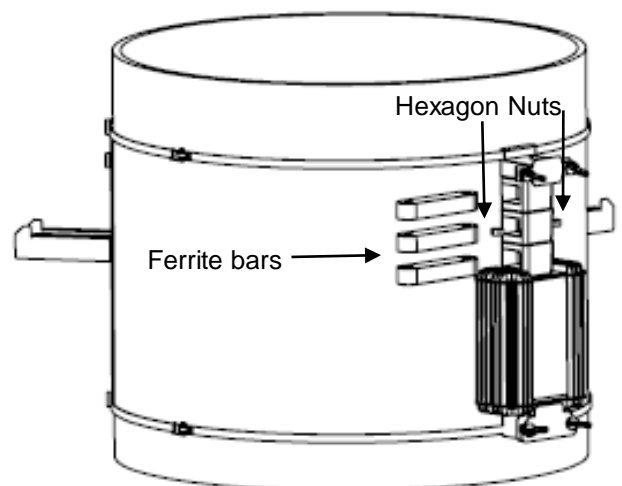

- Take an equal number of ferrites, insert a plastic rod through the holes in both sets of ferrite bars and loosely screw into hexagon nut.
- Secure loosely using a wing nut.
- Repeat on opposite side.

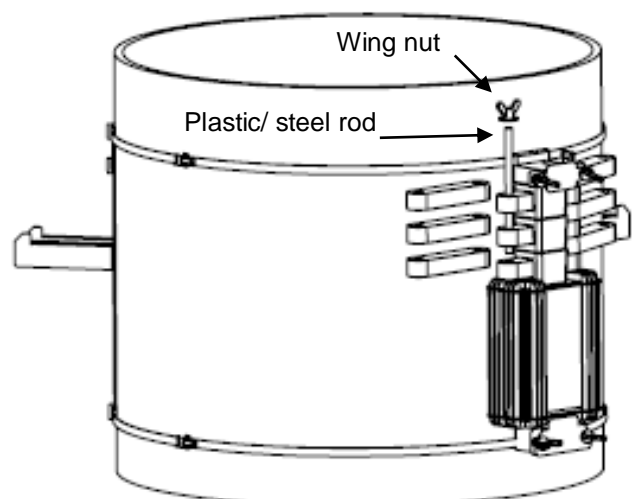

### **WARNING**

The system must be used as specified. Failure to do so will prevent correct operation of device and may impair safety.

# Assembly

## DO NOT POWER UP UNIT UNTIL ALL FERRITES SUPPLIED ARE CONNECTED.

POWERING THE UNITS WITHOUT FERRITES WILL INVALIDATE THE WARRANTY

- Assemble **all** the other ferrites around the pipe according to the mechanical configuration specified for the unit.
- Loosely secure each ferrite with plastic rods and wing nuts.
- Ferrites can be pre-assembled in sections for convenience

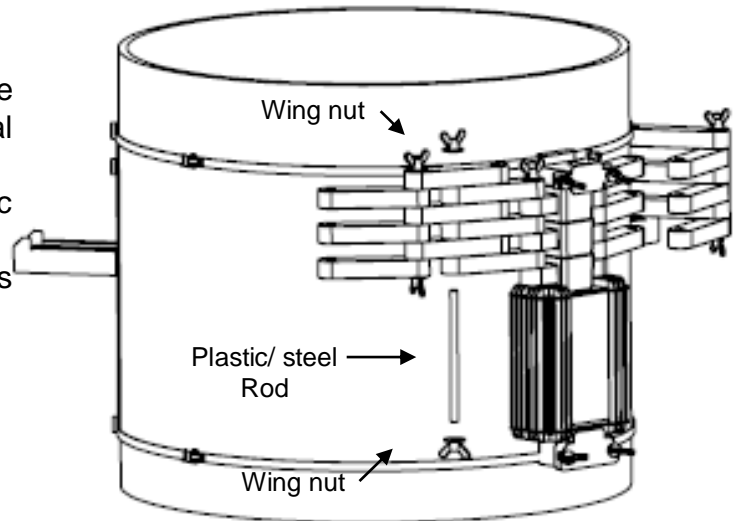

- Adjust position of ferrite support brackets if necessary
- Once the ferrite ring is complete, tighten all wing nuts until hand tight.
- **Do not over tighten as ferrites are fragile.**

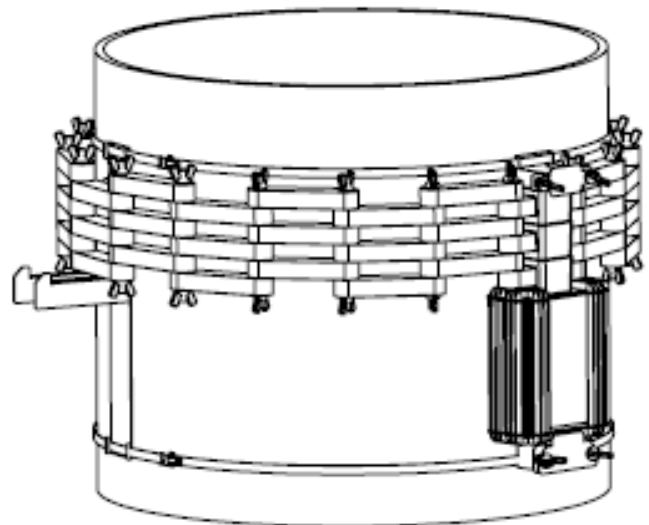

- In accordance with local code and regulations, connect the junction box to the electrical power supply (87V-240V AC).
- Energize the electrical power supply and ensure that the Red and Green LED lights on the unit are glowing brightly.

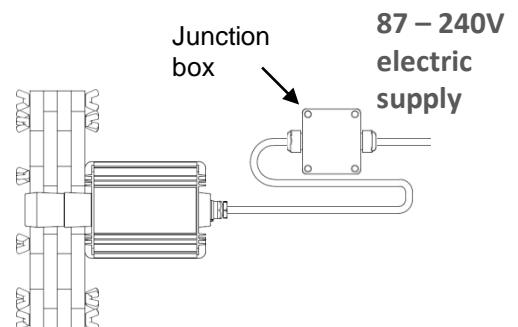

### **WARNING**

The system must be used as specified. Failure to do so will prevent correct operation of device and may impair safety.

# Mechanical Details

<b>Pipe Size OD in Inches</b>	<b>Lines of Ferrite/ Number of Cages</b>	<b>Ferrites per Line</b>	<b>Total Ferrites</b>
8	2	1 long, 9 short	2 long, 18 short
10	2	10	20
12	2	12	24
14	2	14	28
16	3	16	48
18/20	3	18	54
22	3	20	60
24	3	22	66
26	3	24	72

**Larger sizes are available on request.**

The above table is only a guide. Custom units are produced on an individual basis to satisfy the specific needs of each particular application. Hydropath reserves the right to modify the above details as needed.



# Assembly

## MOUNTING THE SURGE PROTECTOR

- The surge protector should be mounted on a safe, convenient location.
- To secure the surge protector to a back plate, first drill four 2.2mm pilot holes as shown.

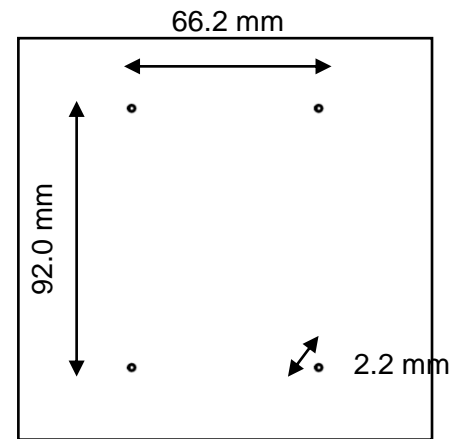

- Remove the surge protector cover by loosening the four screws in the lid.
- Insert the four self-tapping screws into the holes in the surge protector base and into the pilot holes. Tighten until the surge protector is secure.

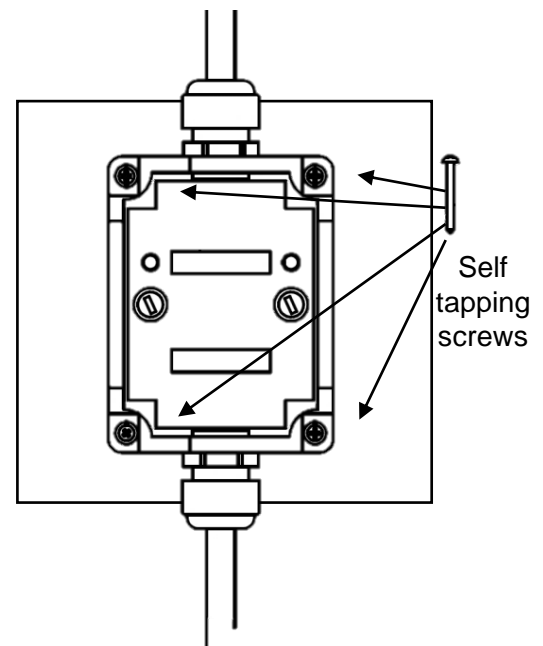

- Once the surge protector base is fixed to the back plate, replace the lid and secure using the four incorporated screws.

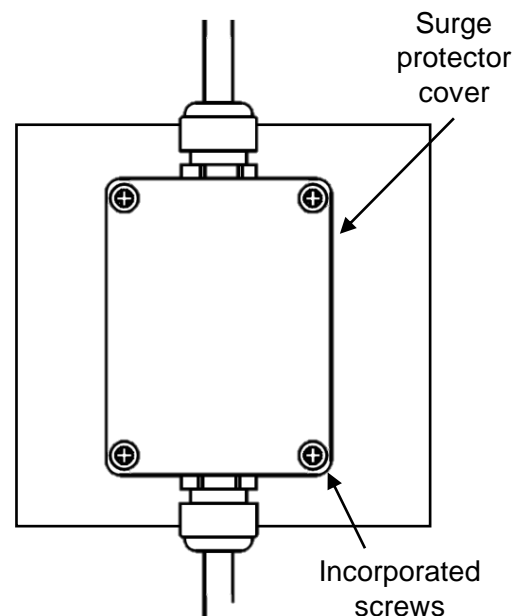

### **WARNING**

The system must be used as specified. Failure to do so will prevent correct operation of device and may impair safety.

# Location Criteria

The Hydropath Marine unit can provide a range of benefits, including protection against limescale, treatment of biofouling, and flocculation of particles. The most effective location for the unit depends on the result desired.

- For protection against Limescale due to heating, the unit should be fitted on the cold feed to where the water is heated.
- For protection against limescale, the unit should be fitted after any pumps or filters as these can degrade the conditioning effect.
- To enhance flocculation or kill bacteria, the ideal location is before the pump feeding a filter.

## Electrical Loops

The unit operates by creating a potential difference on the pipe on either side of the ferrite ring. An electrical loop is created whenever an electrical connection is made from one side of the ferrite loop to the other, e.g. by metal supports, wiring or pipework. A loop will prevent the unit from operating correctly.

This problem can be solved by moving the unit outside the electrical loop. If this is not possible, the metal support brackets can be electrically insulated. Installing the unit on a section of plastic pipe eliminates the possibility of an electrical loop.

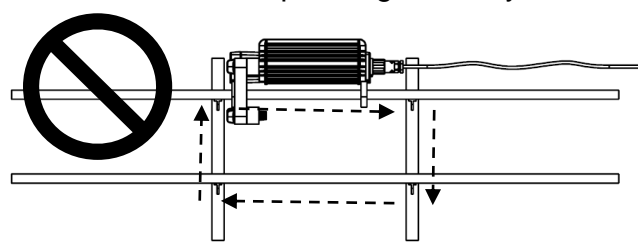

Brackets create loop

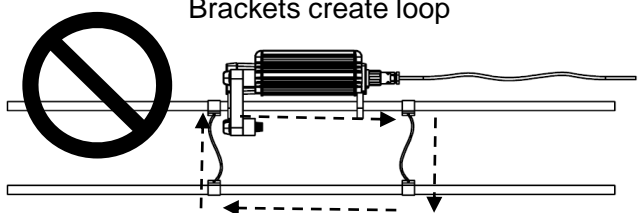

Wiring creates loop

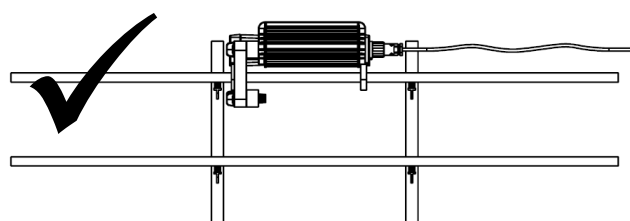

Electrically insulate brackets

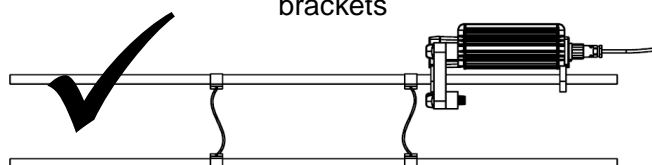

Move unit out of loop

If you are unsure of any details of fitting or installation, please contact your local Hydropath representative for technical support.

## Box Contents

Transducer Unit

User Instructions

Threadlock Glue

Stainless Steel Bracket (3 parts)

Self Tapping Screws x 4

Model Supplied	Ferrites	Stainless Steel Banding	Rods	Hex Nuts	Wing Nuts	Fixing Bracket	Ferrite support Bracket
8"	2 long 18 short	2	10	2	18	1	1
10"	20	2	10	2	18	1	1
12"	24	2	12	2	22	1	1
14"	28	2	14	2	26	1	1
16"	48	2	16	2	30	1	2
18/ 20"	54	2	18	2	34	1	2
22"	60	2	20	2	38	1	2
24"	66	2	22	2	42	1	2
26"	72	2	24	2	46	1	2

**Spares:** 1x Banding Clamp, 2x Thumb Screws, 2x Thumb Nuts, 2x Hex nuts 2x Self Tapping Screws, 2x Fuses ADH9416

***The unit must be registered online to activate the guarantee and warrantee***

*Register at: [www.hydroflow.com](http://www.hydroflow.com)*

**Hydropath Technology Ltd**

C1 Crossgate Drive  
Queens Drive Industrial Estate  
Nottingham, NG2 1LW  
UK